

CE



STORDITORE POLIVALENTE

Polyvalent stunner

Appareil pour étourdir, polyvalent



Art. 091/00

per polli e conigli, scarica 90 Volt

for poultry and rabbit, discharge 90 Volts / *pour poules et lapins, décharge 90 Volts*

1 pz= 80X20X22



PINZA MACELLAZIONE

Pliers to slaughter

Pince à tuer

Art. 043/01

per quaglie-piccioni / for quails-pigeons / *pour cailles-pigeons*

Art. 043/00

per polli-anatre / for chickens-ducks / *pour poules-canards*

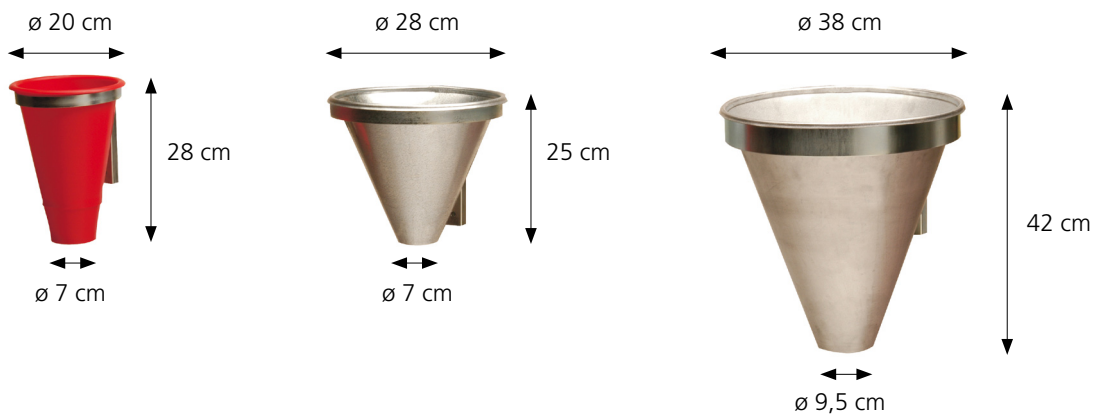

COLASANGUE CON SUPPORTO A MURO

Wall mounted blood strainer

Saignoir fixation murale

Art. 042/50

PICCOLO (per piccoli volatili) / SMALL (for smaller birds) / *PETIT (pour la petite volaille)*

Art. 042/40

MEDIO (per polli e anatre) / MEDIUM (for chickens and ducks) / *MOIEN (poules et canards)*

Art. 042/30

GRANDE (per tacchini e oche) / BIG (for turkeys and geese) / *GRAND (dindes et oies)*



COLASANGUE CON VASCA DI RACCOLTA INOX

Blood strainer with stainless steel tank
Saignoir avec bac de récupération en inox

Art. 042/10 **4 imbuti INOX** / 4 stainless steel funnels / 4 *entonnoirs INOX*
imbuto / funnel / entonnoir : ø cm 24 - ø cm 6 - cm 26 h

Art. 042/20 **6 imbuti PVC** / 6 plastic funnels / 6 *entonnoirs en plastique*
imbuto / funnel / entonnoir : ø cm 20 - ø cm 7 - cm 28 h



VASCA IMMERSIONE INOX, ELETTRICA

Electric stainless steel immersion tank
Bac immersion en inox, électrique

Art. 029/25 **90 Lt**

CE



CE

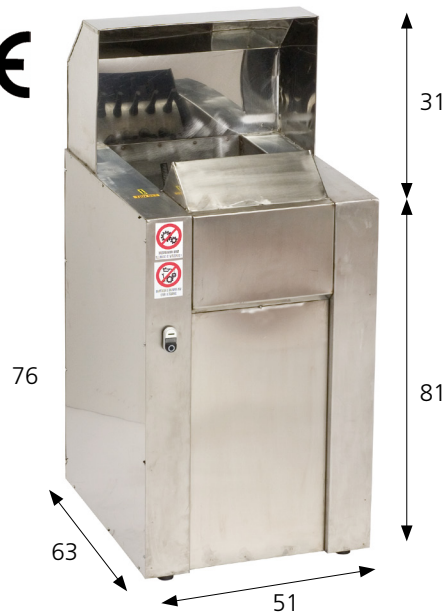

SPENNAPOLLI A UMIDO

Wet-way plucking machine
Plumeuse par voie humide



Art. 030/09-I inox, monofase "MINI" / stainless steel, monophase "MINI" / en inox, monophasée "MINI"

1 pz = 30X59X78

Art. 030/10 inox, trifase / stainless steel, threephase / en inox, triphasée

Art. 030/11 inox, monofase / stainless steel, monophase / en inox, monophasée

RICAMBI

Spare parts / Pièces de réchange

545/00 Dito in gomma / Rubber finger / Doigt en gomme

030/09-I	030/10	030/11
○	○	○

CE

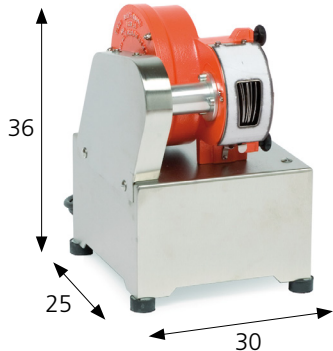

CE



CE



SPIUMATRICE A SECCO

Dry-way plucking machine
Plumeuse à sec



Art. 030/05 6 dischi, per passeracei, quaglie e piccioni, monofase

6 disks, for passerines, pigeons and quails, monophase / 6 disques pour passereaux, pigeons et cailles, monophasée

1 pz = 27x32x38

Art. 030/13 7 dischi, per selvaggina, 220-240 Volt, monofase

7 disks, for game, 220-240 Volts, monophase / 7 disques, pour gibier, 220-240 Volts, monophasée

1 pz = 84x40x43

Art. 030/14 7 dischi, per tutti i tipi di volatili, 220-240 Volt, monofase

7 disks, for every kind of bird, monophase 220-240 V / 7 disques, pour toute la volaille, monophasée 220-240 V

1 pz = 89x57x54

Art. 030/15 7 dischi, per tutti i tipi di volatili, 380 Volt, trifase

7 disks, for every kind of bird, threephase 380 V / 7 disques, pour toute la volaille, triphasée 380 V

1 pz = 89x57x54